

HS SERIES MULTISTAGE PUMPS

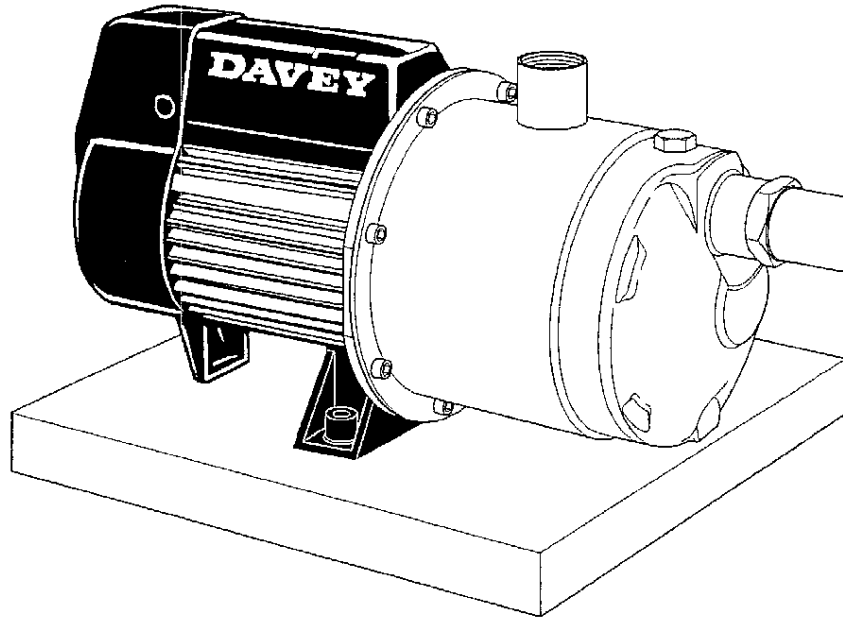

SERVICING INSTRUCTIONS

SI17/1550/1001

Further information can be found in
Hydrascan[®] Trouble Shooting Guide (SI10/500/1000)
and X Series Motors (SI05/500/1000) Servicing Instructions

Note:

Product specifications may change without notice.

Drawings are indicative only, product appearance may change slightly.

® Davey is a registered trade mark of Davey Products Pty Ltd.

© Davey Products Pty Ltd 2001

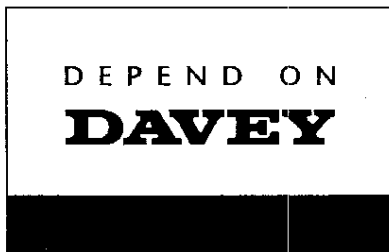

Davey Products Pty Ltd

Member of the GUD Holdings Ltd Group
ABN 18 066 327 517

Head Office and Manufacturing

6 Lakeview Drive,
Scoresby, Australia 3179
Ph: +61 3 9730 9222
Fax: +61 3 9753 4100

Website: www.davey.com.au

Customer Service Centre

Ph: 1300 367 866
Fax: 1300 369 119
E-mail: sales@davey.com.au

Interstate Offices

Sydney – Brisbane – Adelaide
Perth – Townsville

International

6 Lakeview Drive,
Scoresby, Australia 3179
Ph: +61 3 9730 9121
Fax: +61 3 9753 4248
E-mail: export@davey.com.au

Germany

Kantstrasse 47,
04275 Leipzig
Ph: +49 341 301 0412
Fax: +49 341 301 0413
E-mail: DaveyEurop@aol.com

New Zealand

8 Ashfield Street,
Glenfield, Auckland 1310
Ph: +64 9 444 3622
Fax: +64 9 444 2179
Website: www.daveynz.co.nz
E-mail: sales@daveynz.co.nz

USA

1005 N. Commons Drive
Aurora, Illinois 60504
Ph: +1 630 898 6976
Fax: +1 630 851 7744
Website: www.daveyusa.com
E-mail: sales@daveyusa.com









TOOLS REQUIRED

- 5mm Allen Key
- Pozi Drive Screw Driver, 2 point
- 17mm Ring Spanner Socket
- Flat Blade Screw Driver

TORQUE SETTINGS

Casing screws	7-9Nm
Check valve	4-7Nm
Impeller nut	10Nm

WARNINGS

	ALL ELECTRICAL WORK TO BE PERFORMED BY SUITABLY QUALIFIED ELECTRICAL PERSONNEL.
	Always disconnect from electrical supply BEFORE any work is carried out.
	Release pump pressure before undoing any pipe work.
	*NOTE: For protection, the Davey pump motor is fitted with an automatic reset thermal overload, constant tripping of this overload indicates a problem e.g. low voltage at pump, excessive temperature (above 50°C) in pump enclosure.
	WARNING: Automatic reset thermal overloads will allow the pump to restart without warning. Always disconnect the pump motor from the electrical supply before maintenance or repairs.
	WARNING: When servicing or attending pump, always ensure power is switched off and lead unplugged. Electrical connections should be serviced only by qualified persons.
	Care should also be taken when servicing or disassembling pump to avoid possible injury from hot pressurised water. Unplug pump, relieve pressure by opening a tap on the discharge side of the pump and allow any hot water in the pump to cool before attempting to dismantle.
	IMPORTANT: DO NOT USE petroleum based fluids or solvents (e.g. Oils, Kerosene, Turpentine, Thinners, etc) on the plastic pump components or seal components.

HS SERIES MULTISTAGE PUMP ASSEMBLY

1. Fit the ceramic wear face to the stainless steel backplate using a little water on the rubber boot. Ensure that it is square and pushed all the way into the backplate.
2. Put the slinger onto the motor shaft and press it all the way down to the drive endshield. Ensure that it is put on in the right direction with the taper facing forward.

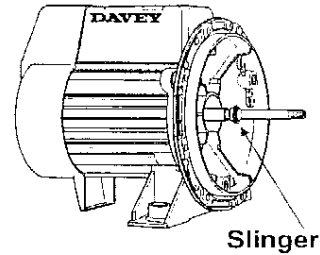

3. Assemble the backplate to the motor and put the mechanical seal on using a little water on the rubber boot and pushing it down over the shaft until the seal faces meet. The carbon seal face should be in contact with the ceramic wear face.
4. Stand the motor vertically on the fan end for ease of assembly of impellers and stage bodies.

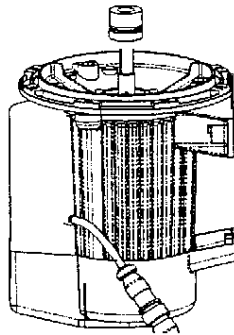

5. Fit the last stage impeller with neck ring facing you and push it down onto the mechanical seal. You will see that there are two flats running the length of the shaft and two corresponding flats in the impeller for better drive.

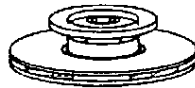

6. Next fit the floating wear ring. This should fit over the neck ring of the impeller.

HS SERIES MULTISTAGE PUMP ASSEMBLY

7. Fit the last stage body. This is the one with the exit slots in it and continue to build with the next impeller and wear ring. There are no clearances or spacers to worry about as the impeller has the spacer inbuilt to minimise the number of components in the pump.

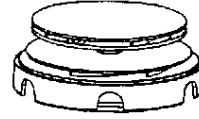

8. Fit the stage body and the next impeller and wear ring. One more stage body and another impeller in the case of a four-stage pump or a spacer in place of the impeller if it is a three-stage pump. The impeller spacer or the impeller should be sitting slightly proud of the shaft stem to enable you to tighten the nut and washer and lock the impellers in position.

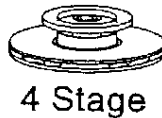

9. Tighten nut to required torque setting.

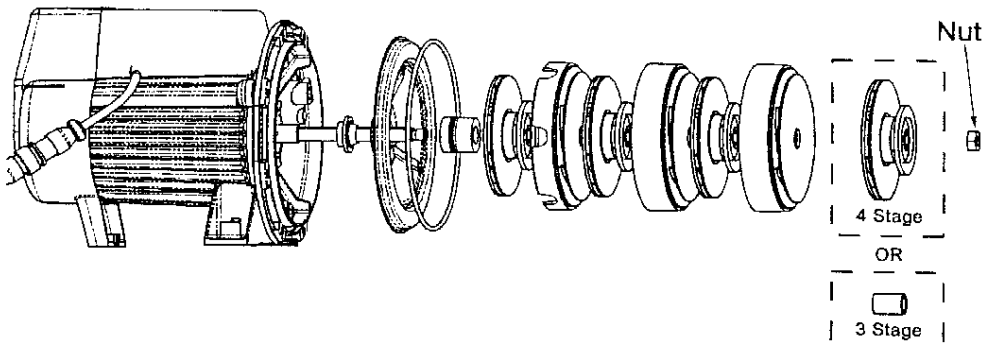

10. Locate the first stage body with the word "top" adjacent to the outlet port of the pump. Note: It is important that this stage body is assembled correctly to aid in the priming of the pump.

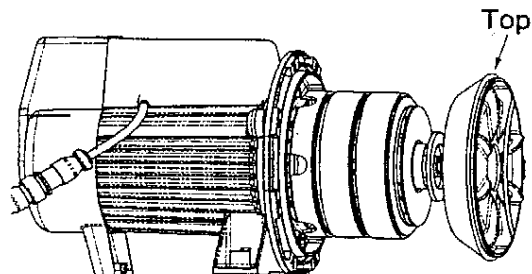

HS SERIES MULTISTAGE PUMP ASSEMBLY

11. Fit the two orings to the assembly and lightly lubricate them with an approved silicon grease.

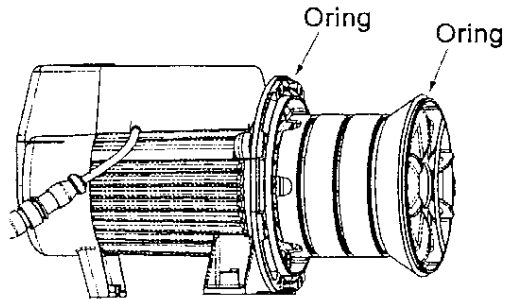

12. Assemble the pump casing with the eight casing screws to the required torque settings.

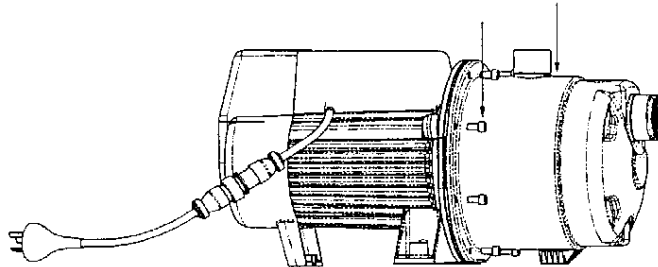

13. Replace the priming plug and oring and screw the non-return valve cartridge into the suction port, in a clockwise rotation using non specified tools (eg. a screwdriver handle, a pair of pliers, a large coin or a flat blade - 20mm wide).

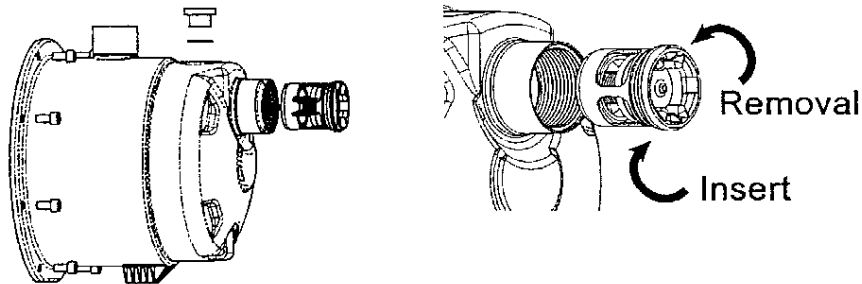

14. Your pump is now ready for water testing.
15. The Davey HS casing design allows for the motor to be fitted at 90 degrees to the outlet port to cater for wall mounting of the motor. The outlet port and first stage body should be uppermost during this configuration.

HS SERIES MULTISTAGE PUMP DISASSEMBLY

1. Disconnect the power supply and release the pump pressure before removing the pump to do any repairs.
2. Remove the eight casing screws with a 5mm allen key turning anti-clockwise. Sit the pump on the fan cowl for easier removal of the screws.
3. You may have to put a flat blade screwdriver between the casing and the back plate to pry it off.
4. The first stage body should lift off and it should also have an oring with it. If it is not still attached to the stage body, check inside the casing to see if it is stuck to the inside. If so remove it and check for flat spots and tears.
5. You will now see a stainless steel nut that holds the rest of the pump assembly in place. This is removed with a 17mm ring spanner. You will need to sit the pump horizontally and remove the fan cowl. Place a flat blade screwdriver into the slot in the rotor, hold it tight and give the spanner a sharp tap with a softhead mallet to loosen the impeller screw.
6. Remove the impellers wear rings and stage bodies and check for wear or rub marks.
7. Remove the mechanical seal and casing oring. Check for wear or signs of heat on the seal faces and rubber boot. Check the oring for tears or flat or pinched spots.
8. The back plate can be removed by inserting a small punch through the holes in the motor end shield and tapping it off. Remove the slinger from the shaft. Check, clean or replace all parts before you reassemble the pump.